

Restrained Spring Mount - Model: SRSM 25 mm Standard Deflection

1. Compliance:

- 1.1 Designed to BS 1726 -1 : 1987
- 1.2 Tolerance to BS 1726-1 : 2002
- 1.3 SAE and Ashrae Guidelines for Vibration Isolation

2. Application:

Isolation of Seismic Vibrations for Pumps, Boilers, Cooling Tower, Compressors etc.

3. Product Features:

- 3.1 Multi Directional Restraint with Vertical Limit Stops.
- 3.2 Replaceable Springs.
- 3.3 Epoxy Powder Coated / Hot Dipped Galvanized body.
- 3.4 Springs have a deflection of 25 mm at Rated Load and are designed with 50% overload capacity to compensate for unexpected Load variations and to reduce Operating Stress.
- 3.5 Steel Frame with restrained Neoprene Snubber and Dual Vertical Restraint Plates limit movement of the connected machinery upto maximum 3 mm.
- 3.6 Provided with Neoprene Base Pad which can isolate High Frequency Vibrations of audible range.
- 3.7 Built-in Levelling arrangements.
- 3.8 The Restraining System is capable to withstand 1.0 g Acceleration Force.
- 3.9 Springs and Casings have Epoxy Powder Coated finish, rated to withstand 1000 hours of Salt Spray Testing as per ASTM B117 Test Procedure.
- 3.10 The Horizontal Stiffness of Springs are 80% of Vertical Stiffness. The working deflection shall be maximum 60% of deflections at Rated Load.

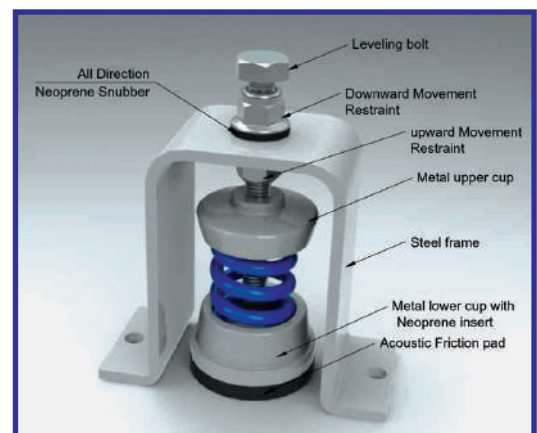

SELECTION TABLE - FOR 25 mm DEFLECTION RESTRAINED SPRING MOUNT
(Table No. : C-35-01)

Isolator Model	Rated Load (kg)	Colour Code	Dimensions (mm)					
			L	W	H*	BC	D	d
SRSM-A25	25	Green	135	63	163	110	M10	12
SRSM-A50	50	Black						
SRSM-A75	75	Yellow						
SRSM-A100	100	Blue	135	63	163	110	M10	12
SRSM-A150	150	Grey						
SRSM-A200	200	Orange						
SRSM-B200	200	Black	151	75	170	125	M10	12
SRSM-B250	250	Yellow						
SRSM-B300	300	Blue						
SRSM-B400	400	Grey	189	90	200	150	M12	14
SRSM-C400	400	Brown						
SRSM-C500	500	Grey						
SRSM-C600	600	Orange	197	90	220	156	M12	18
SRSM-C700	700	Green						
SRSM-C800	800	Pink						
SRSM-C1000	1000	White						
SRSM-C1200	1200	Purple						
SRSM-C1400	1400	Purple / Yellow						
SRSM-C1600	1600	Purple / White						

* Represents average free height in each grouping of models. Height of some models in group may vary slightly from this figure.

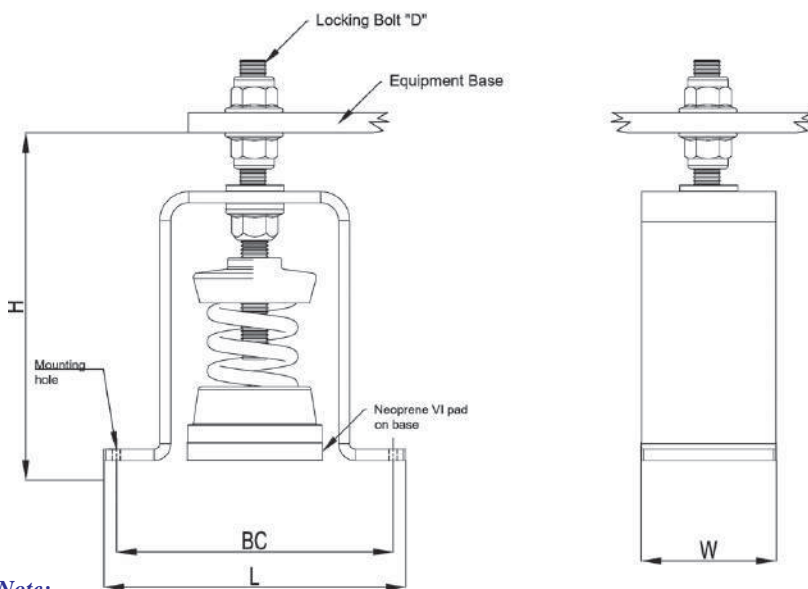

Note:

- Due to policy of continual improvement, the specifications are subject to change without prior notice.
- Measurements are subject to 5% tolerance.
- To achieve good sound suppression, do not overload fitting.

